

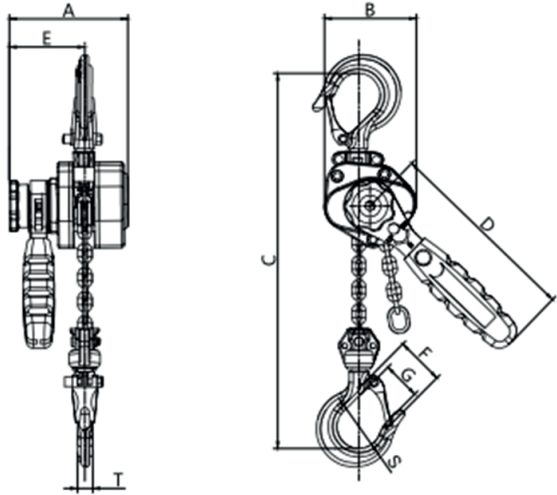

THE NEW LITTLE BEAUTIES

FIND BEAUTY IN THE SMALL THINGS

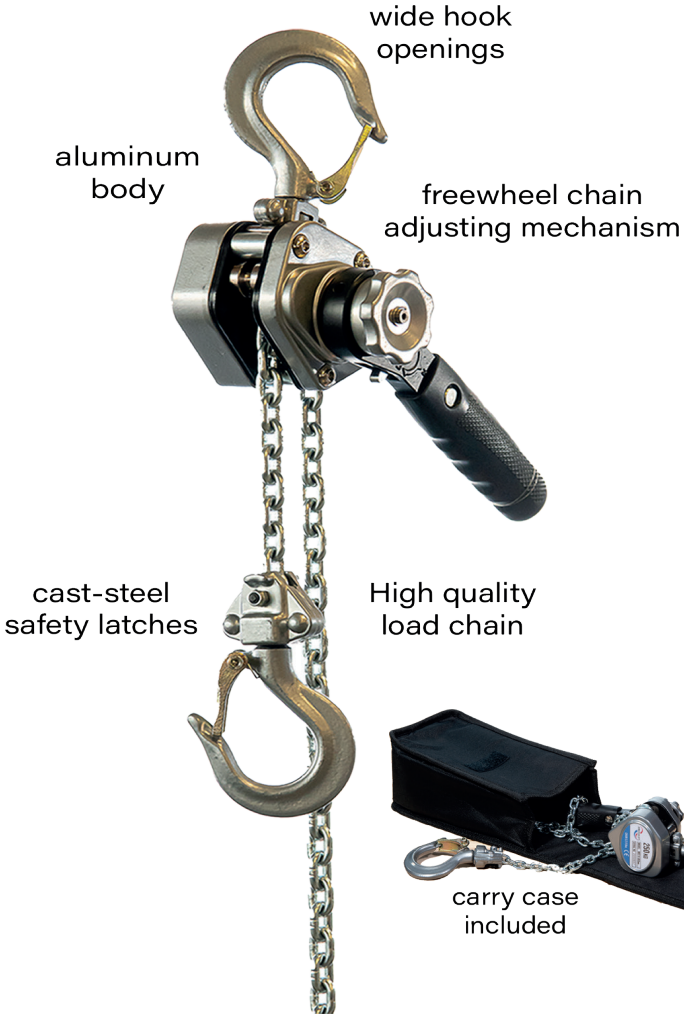



Rated Load (W.L.L.)	(kg) [t]	250 [0.25]	500 [0.5]
Product Code		MRT-H-003	MRT-H-005
Standard lift	(m)	1.5	1.5
Pull to lift full load	(N) [kgf]	200 [20]	240 [24]
Load chain diameter	(mm)	3.2x9	4.3x12
Test load	(kg)	375	750
Net weight	(kg)	1.55	2.55
Weight for additional one meter of lift	(kg/m)	0.2	0.4
	A	90	98
	B	68	81
	c	200	250
Dimensions (mm)	d	150	172
	E	56	62
	F	35.5	42
	G	20	21
	S	32	34.5



INFORMATION & PRICING



SCAN ME